



NEXPACK™ - NEXT GENERATION PACKAGING MACHINES

NEXPACK - 3000

Single Head Pouch Packaging Machine

SPEED: 3000 Pouches/Hr



What Is **NEXPACK** Series

- Total S.S. Machine
- No Cooling Water
- No Teflon Tape
- No Heating Element
- Patented Improved Sealing
- Patented Energy Utilization
- Patented Part Designs

NEXPACK is Registered Trade Mark Of PGP Ngtech Pvt. Ltd.



PGP NGTECH PVT. LTD.™

Corporate Office & Factory :
Khedekar Ind. Estate, S. No. 38/1, Katraj-Narhe-Dhayari Road,
Behind Pari Towers, Narhe, Pune - 411041, INDIA

An ISO 9001 : 2015 Certified Company

Web: www.pgpngtech.com

Email: info@pgpngtech.com

Mob: +91 9422301357, 8308562020

Salient Features:

- All SS construction including structure
- No cooling water
- High Filling Accuracy System
- Advance sealing system
- Equipped with Touch Screen HMI & PLC
- Servo Motors For Pouch Film Pulling
- Motorized Film Unwind System
- One Touch Settings Enabled
- Stops Automatically on Faults

Technical Specifications of 'Nexpack - 3000'

- Machine Dimensions: 870mm(W), 1125mm(D), 2700mm(H)
- Pack Quantity Range: 100 ml to 1000 ml
- Accuracy: $\pm 0.5\%$
- Packaging Material: LDPE/LLDPE
Film Width: $325 +2/-0$ mm, Reel Dia: 350 mm
- Package Style: Center sealed pillow pouch
- Speed: Up to 3000 pouches
(*Output & accuracy is dependant upon film and product**)
- Air Consumption: 115 LPM or 7 m³/hour @ 5 kg/cm²
- Power: 400 V $\pm 1\%$ AC 3 Phase, 50 Hz, 4 Wire (Stabilized)
- Power Consumption: 1.0 KWH Appx

Optional Accessories

- Photomark Scanner
- Date Batch Coder
- Extended Legs
- Tray stand & Platform

Product Applications

- Plain Milk
- Flavored Milk
- Tak / Lassi
- Drinking Water
- Juice Drinks



Detailed specifications along with MOC on request

Tentative Pack Sizes

Quantity	Width	Length
200 ml	150 mm	100 mm
500 ml	150 mm	155 mm
1000 ml	150 mm	230 mm

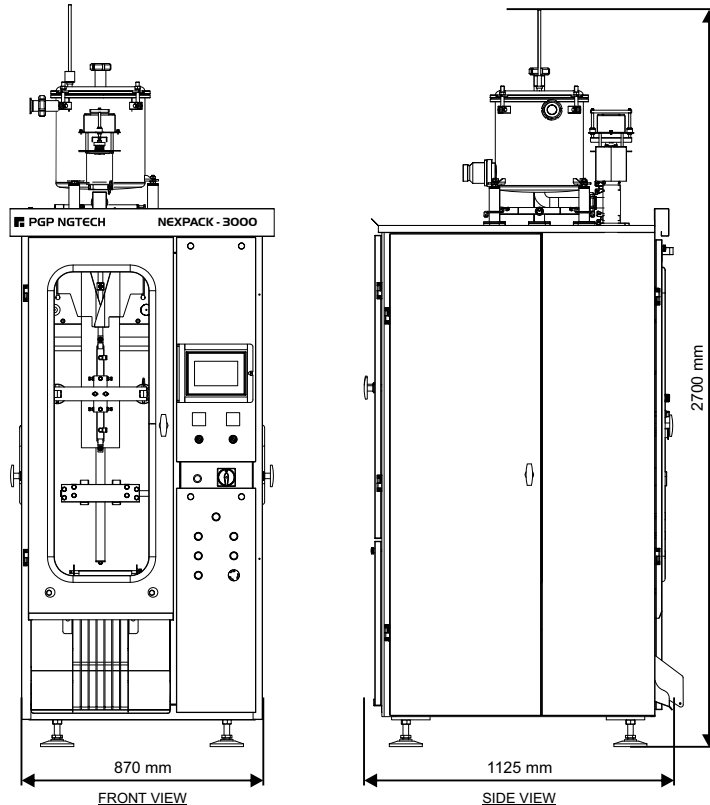

Pouch Format



CSPP 500 ml



Due to continuous R & D, Actual Photos, Specifications & Dimensions subject to change.



PGP NGTECH PVT. LTD.

Corporate Office & Factory :
Khedekar Ind. Estate, S. No. 38/1, Katraj-Narhe-Dhayari Road,
Behind Pari Towers, Narhe, Pune - 411041, INDIA

An ISO 9001 : 2015 Certified Company

Web: www.pgpngtech.com

Email: info@pgpngtech.com

Mob: +91 9422301357, 8308562020